

BROADCAST[®]
t o o l s **INC**
PROBLEM SOLVED

Installation and Operation Manual

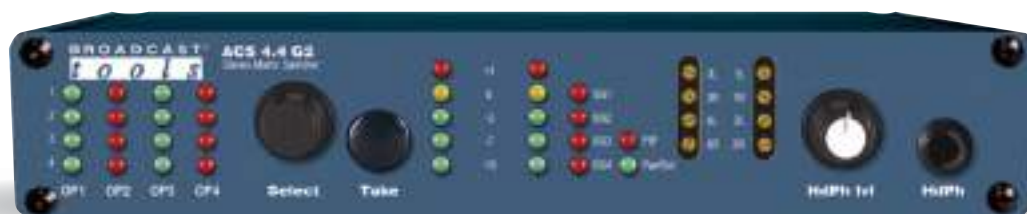

ACS 4.4 G2
Four Input, Quad Output Stereo Audio Matrix Switcher

Firmware Version 0.3 and above

Manual update: 12/15/2021

If you need a firmware upgrade, contact Broadcast Tools[®]

No part of this document may be reproduced or distributed without permission.
ALL SPECIFICATIONS AND FEATURES FOR THIS PRODUCT ARE SUBJECT TO
CHANGE WITHOUT NOTICE

NOTE: We recommend the use of Chrome, Firefox or Safari as your browser.

Due to the dynamic nature of product design, the information contained in this document is subject to change without notice. Broadcast Tools, Inc., assumes no responsibility for errors and/or omissions contained in this document. Revisions of this information or new editions may be issued to incorporate such changes.

*Broadcast Tools[®] is a registered trademark of Broadcast Tools, Inc.
All Sentinel[®] labeled products are registered trademarks of Broadcast Tools, Inc.
Copyright[®] 1989 - 2022 by Broadcast Tools, Inc. All rights reserved.
No part of this document may be reproduced or distributed without permission.*

Visit www.broadcasttools.com for important product update information.

Table of Contents

Section Title	Page #
Introduction	3
Safety Information	3
Who to Contact for Help	3
Product Overview	4
Features/Benefits	4
Applications	4
Inspection	5
Installation	5
Surge Protection	5
Mounting	5
Power Supply Connection	5
UPS standby power system	5
Chassis Ground Connection	5
Installation/Operation	6
Front Panel LEDs/Controls	6
Audio Mix Modes	6
RS-232 Serial Port (RJ-11 Jack)	7
Audio Inputs/Outputs	7
RJ45 Audio Pinout	8
Cable Preparation	9
Audio Input Expansion	9
Audio Level Adjustment	9
PIP/Trigger Inputs	10
Silence Sensors	10
Open Collector Outputs	11
Relay Outputs	11
Configuration Dip-switch setup	12
Serial Operation	14
RS-232 Control	14
Serial commands	15
Menu Operation	19
Specifications	20
Warranty	21
Front and rear panel drawings	Appendix
Configuration jumpers and DIP-switch layout	Appendix
Fractional schematic	Appendix

WEBSITE:
 Visit our web site for
 product updates and
 additional information.



INTRODUCTION

Thank you for your purchase of a Broadcast Tools® ACS 4.4 G2 Four Input, Quad Output Stereo Audio Matrix Switcher (referred to as the ACS 4.4 G2 throughout this manual). We are confident that this product will give you many years of dependable service. This manual is intended to give you all the information needed to install and operate the Broadcast Tools® ACS 4.4 G2.

SAFETY INFORMATION

Only qualified technical personnel should install the ACS 4.4 G2. Any attempt to install this device by a person who is not technically qualified could result in a hazardous condition to the installer or other personnel or damage to the ACS 4.4 G2 or other equipment. Please ensure that proper safety precautions have been taken before installing this device. If you are unfamiliar with this type of equipment, please contact a properly qualified engineer to handle the installation and setup of the ACS 4.4 G2. Broadcast Tools, Inc., is unable to support NON-Broadcast Tools software, hardware or NON-Broadcast Tools computer/hardware/software problems. If you experience these problems, please research your hardware/software instruction manuals or contact the manufacturers technical support department.

WHO TO CONTACT FOR HELP

If you have any questions regarding your product or you need assistance, please contact your distributor from whom you purchased this equipment. If you would like more information about BROADCAST TOOLS® products, you may reach us at:

Broadcast Tools, Inc.

131 State Street
Sedro-Woolley, WA 98284-1503 USA
Voice: 360.854.9559
Fax: 866.783.1742

Internet Home Page: www.broadcasttools.com
E-mail: support@broadcasttools.com

THANK YOU FOR CHOOSING
BROADCAST TOOLS® BRAND PRODUCTS!

Broadcast Tools is a Veteran Owned Business



Designed, Assembled and Supported in WA State, USA



Broadcast Tools® Products, as with any electronic device, can fail without warning. Do not use this product in applications where a life threatening condition could result due to failure.



This manual should be read thoroughly before installation and operation.

WEBSITE:

Visit our web site for product updates and additional information.



Product Description

The Broadcast Tools® ACS 4.4 G2 provides matrix audio switching of 4 stereo inputs to 4 stereo outputs. Matrix switching allows any/or all inputs to be assigned to any/or all outputs. The ACS 4.4 G2 may be controlled via its front panel rotary encoder control knob and TAKE switch, contact closures, open collectors, logic and/or the multi-drop RS-232 serial port (USB or Ethernet optional). Installation is simplified with RJ45 audio jacks for input and output connections and plug-in euroblock screw terminal connectors for expansion and remote control.

Features

- 4x4 balanced analog stereo matrix audio switcher.
- Front panel rotary encoder control knob and separate “TAKE” push button are provided for input to output channel selection.
- 16 input “PIP” (GPI / Triggers) port (or remote control) with front panel LED indicator.
- Multi-drop RS-232 serial port (USB and/or Ethernet optional) and ASCII command set for computer/automation control.
- Three audio switching modes: Interlock, overlap, and mix.
- Internal silence sensors monitor each output and provide front panel LED silence indicators and silence alarm open collector outputs. Trip level, silence delay and restore duration timing are user configurable.
- Front panel stereo LED VU meters. (Output one only)
- Stereo headphone output with front panel headphone jack and level control. (Output one only)
- Configurable power-up selection of inputs to outputs, mute or last source selected.
- Four open collector outputs act as status tally or controllable via serial burst commands.
- Two SPDT relay outputs with selectable function.
- Front panel multi-turn input level trimmers and internal single turn output level controls.
- Electronically balanced stereo inputs and outputs with low noise, low distortion circuitry.
- Most configuration options are via the internal dipswitches.
- Multiple units may be cascaded to expand audio inputs.
- RJ45 audio jacks for audio I/O and plug-in euroblock screw terminals for audio expansion and remote-control connections.
- Fully RFI proofed.
- Includes PS-1515 +/-15VDC universal desktop power supply (100-240 VAC, 46-63 Hz input) with IEC AC inlet.
- Up to two units may be mounted on the optional RA-1 rack shelf. Desktop and wall mounting is also possible.

Applications

Broadcast automation audio switcher with trigger inputs, studio source selector, IP codec source selector, and transmitter site (STL) source selector.

WEBSITE:

Visit our web site for product updates and additional information.



DESCRIPTION

Inspection

Please examine your ACS 4.4 G2 carefully for any damage that may have been sustained during shipping. If any is discovered, please notify the shipper immediately and retain the packaging for inspection by the shipper. The package contains the ACS 4.4 G2, a PS-1515/IEC, +/-15 VDC desktop power supply, and a reversed modular serial cable with the “S9” 9-pin D-Sub adapter. Manuals may be downloaded from our web site.

Mounting

The ACS 4.4 G2 is designed to be rack mounted in the optional “RA-1” 19” 1-RU rack shelf. It should be mounted in an area that is accessible from the rear and preferably away from sources of heat. We recommend that you bench test and become familiar with the operation of the unit before permanently installing it.

Power Supply Connection

Insert the universal AC input PS-1515/IEC DC switching power supplies latching 3-pin connector into the power receptacle on the rear panel of the ACS 4.4 G2. When ready, plug the power supply into the appropriate AC receptacle. ⚡ CAUTION! Only use the power supply provided with this product.

UPS Standby Power System

We recommend that you power your ACS 4.4 G2 from an uninterruptable power supply (UPS) system. A UPS, like the “BE600M1” from APC, helps minimize the risk to the ACS 4.4 G2 and provides power during a power outage.

Chassis Ground screw (CHS GND)

The #4-40 sized chassis ground screw should be tied to the station (house) or system ground.



Installation of the ACS 4.4 G2 in high RF environments should be performed with care. Shielded cable is suggested for all control, audio inputs and outputs. All shields should be tied to the “GND” terminal on each channel. The station ground should be connected to the chassis ground screw (GND) located on the right side of the chassis as viewed from the rear. For lightning protection devices, check out www.polyphaser.com and www.itwlinx.com.

It is recommended that all cables connected to the ACS 4.4 G2 be looped through ferrite cores to suppress RF. Surge protection with RF filtering such as the Tripp Lite “ISOBAR 4” is also suggested for the power supply.

Front Panel

The ACS 4.4 G2 utilizes a 1/2-rack aluminum enclosure (8.50" x 7.10" x 1.576" (WDH). The front panel features one rotary encoder control knob, a take button, eight input level trimmers, 22 LED indicators, a LED VU meter, a 1/4" T/R/S stereo headphone jack and headphone level control.

The switcher can be configured for the following audio switching modes via dipswitch:

Overlap (default): Overlaps the selected (first) audio input with the audio from the new audio input while the button for the new source is held down. Both channels will be fed to the output until the button for the new audio input is released, at which time the first audio source will be switched off.

Interlock: Connects one input to an output, selecting another input disconnects all other inputs from that output.

Mix: Multiple inputs may be routed to the output – Push the take button once to connect, to mute press the take button again.

Front Panel LEDs

Front Panel LED's	Number	Activation Event/Mode	Activation Behavior
Input connected to "OP 1"	4 Green	State of connection	ON if connected
Input connected to "OP 2"	4 Red	State of connection	ON if connected
Input connected to "OP 3"	4 Green	State of connection	ON if connected
Input connected to "OP 4"	4 Red	State of connection	ON if connected
"SS" 1-4, Silence Alarm on each output.	4 Red	Duration of silence	ON when silence detected.
"PIP" (Triggers) input activated.	1 Red	Any valid "PIP" / Trigger input, when enabled.	ON when PIP inputs triggered.
"PWR/Ser" Status	1 Green	Valid power and/or serial data.	ON, but flickers with serial data activity.

Front Panel Operation

Action	
<p>[?] To select an input/output channel. Twist the encoder knob clockwise to move the blinking LED to the next input/output channel.</p>	<p>The input and output LED will blink indicating which input and output channel may be selected. To select, simply press the "TAKE" push button.</p>

WEBSITE:

Visit our web site for product updates and additional information.



Rear Panel

The ACS 4.4 G2's rear panel hosts the audio and remote-control connectors, chassis ground terminal, multi-drop RS-232 modular connector, and 3-pin universal power supply connector. Installation is simplified with RJ45 jacks for balanced audio I/O and plug-in euroblock screw terminals for audio expansion and remote control.

RS-232 Serial Port (RJ-11 Jack)

This RJ-11 jack is used to connect the ACS 4.4 G2 to a computer's COM port for RS-232 serial operation using the included reverse modular cable with 9-pin "S9" female D-sub adapter. If your PC does not have a built-in RS-232 serial port but does have USB, then a USB-to-serial adapter cable is a good way to add USB serial capability. We recommend USB-to-serial adapter cables that use the FTDI chipset and have had good results with the model "SBT-FTDI" from Sabrent.

Audio Inputs

Each of the four stereo inputs are balanced bridging (20K Ω) at a nominal line level of +4dBu. Input connections should be made to the + and - input pins for balanced operation, or to the + input pins and grounding the - side for unbalanced input operation. Front panel multi-turn level trimmers are provided for adjustment of each input channel.

Audio Outputs

The ACS 4.4 G2 provides four balanced low impedance stereo outputs. Output connections should be made to the + and - outputs for balanced operation, or to the + output and ground for unbalanced output operation. The output levels may be adjusted with the internal single-turn trimmers. **CAUTION:** In no case should either the + or - OUTPUTS be connected to ground.

Connecting the Audio Inputs and Outputs

The input channels are numbered from 1 through 4 on the rear panel. The ACS 4.4 G2 interfaces to external audio equipment through RJ45 jacks using the standard audio pinout. Follow the RJ45 connection tables below for the desired audio input and output connections, which appear on the rear of the unit.

Input 1 RJ45	Input 3 RJ45		Output 1 RJ45	Output 3 RJ45
Input 2 RJ45	Input 4 RJ45		Output 2 RJ45	Output 4 RJ45

RJ45 Audio Input Jacks (J5)

RJ45 Audio Output Jacks (J7)

WEBSITE:

Visit our web site for product updates and additional information.



RJ45 Audio Jack Pinout:

The input and output RJ45 jacks conform to the RJ45 audio wiring standards. Please use shielded twisted pair Cat5e or Cat6 cables and connectors (STP).

Function:	Wire Pair:	RJ45 Pins:
Left+	White/Orange	1
Left-	Orange/White	2
Right+	White/Green	3
Right -	Green/White	6
n/c	White/Blue	5
GND	Blue/White	4
n/c	White/Brown	7
n/c	Brown/White	8
GND	Shield	Shield

CAUTION!

Installation of the ACS 4.4 G2 in high RF environments should be performed with care. The station ground should be connected to the designated “Chs Gnd” ground terminal.

WEBSITE:

Visit our web site for product updates and additional information.



Installation

Cable Preparation

The terminals block connectors used for input channel expansion and remote-control connections accommodate wire sizes from 16 - 28 AWG, solid or stranded. Before installing a wire, remove the euro-block screw terminal plug and turn each terminal capture screw fully counterclockwise. Strip each conductor to a length of 0.25” and insert the conductor fully into the terminal. Turn the capture screw fully clockwise to secure the conductor. Verify that no bare/stray wires are exposed.

Input Channel Expansion

Input expansion may be accomplished by using two ACS 4.4 G2 switchers and connecting a shielded cable between the first ACS 4.4 G2’s EXT1L unbalanced input terminal and the second units’ output. The cable shield should be connected to the ground terminal. Follow the same procedure for the EXT1R channel. The above example provides 8 inputs, with the first switcher providing the main output.

(Top row, TB-1)

EXT1L	EXT1R	Grd	EXT2L	EXT2R
EXT3L	EXT3R	Grd	EXT4L	EXT4R

(Bottom row, TB-1)

Audio Input and Output Level Adjustment

Once the input and output connections have been made, the input levels can be adjusted. The switcher is factory set for unity gain so normally no additional adjustment is necessary. Recommended average input levels would be in the range of 0 dBu to +8 dBu. Should input levels need to be changed, trimmers are accessible from the front panel. Each stereo input is labeled and has two trimmers, one for the left channel one for the right channel.

Calibrating audio levels on the switcher:

- 1 – Remove power from the unit and remove the circuit board from the chassis by unscrewing the four rear panel screws and sliding the rear panel and circuit board out of the back of the chassis.
- 2 – Feed a reference signal into input channel 1. A 2 kHz sine wave test tone at +4 dBu is used at the factory. Connect a Hi-Z dB meter to the TEST jack JP2.
- 3 – Re-apply power. Adjust the left and right input 1 trimmers to a zero level on your dB meter.
- 4 – Disconnect the dB meter from JP2 and connect a balanced stereo input dB meter to the output. Adjust the output trimmer R68 (Output 1 Left) and R83 (Output 1 Right) for the desired output level. +4 dBu is set at the factory. Make sure input 1 to output 1 is selected using the front panel controls. Repeat this step for Output 2 (R97, R112), Output 3 (R128, R141), and Output 4 (R156, R170).
- 5 – Once input 1 and the four outputs have been calibrated the rest of the inputs maybe calibrated by routing them to output 1 and adjusting the input level trimmers.

WEBSITE:

Visit our web site for product updates and additional information.



PIP / Trigger Inputs

The 16 “PIP” (GPI/Trigger) inputs are used to monitor external contact closures and pass that information back to the control/automation computer. Response time is set for 50ms minimum by default but may be configured from 40ms to 2.54 seconds. The inputs are pulled high to 5 volts through internal 22KΩ resistors and activated by pulling the input low, to ground. These inputs supply status to any polling serial device (when the unit ID is set to 0 (ZERO), no polling of inputs is required. Polling IS required if the unit ID is set above zero).

(Top row, TB-2)

Remote Control Mode (SW2-8 = OFF)

Pin	Function	Label
1	Input	IN 1 to OP 1
2	Input	IN 2 to OP 1
3	Input	IN 3 to OP 1
4	Input	IN 4 to OP 1
5	Input	IN 1 to OP 2
6	Input	IN 2 to OP 2
7	Input	IN 3 to OP 2
8	Input	IN 4 to OP 2
9	Input	IN 1 to OP 3
10	Input	IN 2 to OP 3
11	Input	IN 3 to OP 3
12	Input	IN 4 to OP 3
13	Input	IN 1 to OP 4
14	Input	IN 2 to OP 4
15	Input	IN 3 to OP 4
16	Input	IN 4 to OP 4

PIP Mode (SW2-8 = ON, Default)

Pin	Function	Label
1	Input	PIP 1
2	Input	PIP 3
3	Input	PIP 3
4	Input	PIP 4
5	Input	PIP 5
6	Input	PIP 6
7	Input	PIP 7
8	Input	PIP 8
9	Input	PIP 9
10	Input	PIP 10
11	Input	PIP 11
12	Input	PIP 12
13	Input	PIP 13
14	Input	PIP 14
15	Input	PIP 15
16	Input	PIP 16

Silence Sensors

The each of the four outputs on the ACS 4.4 G2 are monitored by a silence sensor. The factory default alarm delay is set at 10 seconds, with a threshold of -25 dB, while the restore time is set at two seconds. Upon silence delay detection, the appropriate “SS” led will illuminate and the corresponding (SSx) open collector will go logic low for the duration of the silence. The sensor may be programmed for:

- Number of seconds of silence (delay) that must be present before an alarm state is reached or terminated.
- Number of seconds that valid audio (restore) must be present before an alarm state is cleared.
- Alarm threshold of: -20, -25, -30, -35, or off (disabled).

WEBSITE:

Visit our web site for product updates and additional information.



Status Open Collector and Silence Sense Open Collector Outputs

The ACS 4.4 G2 has four open collector status outputs labelled, OC1, OC2, OC3, and OC4 respectively. The status open collector (OCx) output for the selected channel will go low providing a return (ground) for an LED indicator, TTL/CMOS logic, or relay. External pull-up resistors may be required in some installations, voltages must be limited to 6 VDC at 100 mA maximum.

In addition to the status open collector outputs, four silence sense alarm open collector outputs are also present labelled SS1, SS2, SS3, and SS4 respectively. When the output silence sensor is enabled, the open collector will go low when silence is detected and stay low until valid audio returns to the output. External pull-up resistors may be required in some installations, voltages must be limited to 6 VDC at 100 mA maximum.

The open collector outputs are located on pins 1-8 of the bottom TB-2 terminal block connector.

(Bottom row, TB-2)

Pin #	Function	Label
1	Output	OC1 (Open collector out 1)
2	Output	OC2 (Open collector out 2)
3	Output	OC3 (Open collector out 3)
4	Output	OC4 (Open collector out 4)
5	Output	SS1 (Silence sensor out 1)
6	Output	SS2 (Silence sensor out 2)
7	Output	SS3 (Silence sensor out 3)
8	Output	SS4 (Silence sensor out 4)

Relay Outputs

The ACS 4.4 G2's two SPDT relay outputs can be used to control external equipment using contact closures. The relays are controlled by serial commands. Each relay can be commanded by serial command to: pulse, latch on, or latch off. The relay connections are located on pins 9-16 of the bottom TB-2 terminal block connector.

(Bottom row, TB-2)

Pin #	Function	Label
9	Output	K1NO (Normally Open)
10	Output	K1CM (Common)
11	Output	K1NC (Normally Closed)
12	Output	K2NO (Normally Open)
13	Output	K2CM (Common)
14	Output	K2NC (Normally Closed)
15	Output	OCx
16	Ground	GND

WEBSITE:

Visit our web site for product updates and additional information.



Setting Configuration Dip-switches

The ACS 4.4 G2 is equipped with an 8-position configuration dipswitch labelled SW2. The dipswitch specifies a 2-bit unit ID, serial baud rate, audio modes (mix, interlock, overlap), and other features listed below. The unit must be removed from the case to access the Dipswitches. Remove power and any cables from the unit. Use a Philips screwdriver to remove the screws holding the rear panel, along with the ground screw. Slide the circuit board assembly out the back of the chassis. Located the dipswitch labeled SW2. Set the Dipswitches for the desired configuration listed below. When finished, carefully slide the circuit assembly back into the chassis, reinstall the rear panel with the four panel screws. Follow the configuration description below.

“OPTIONS” SW2 Dip-switch Functions

1	OFF	Unit ID binary address 1 (Default ID = 0)
2	OFF	Unit ID binary address 2
3	OFF	Baud rate (Default) OFF = 9600 / ON = 38400
4	OFF	Stereo Audio Switching (Default = Overlap)
5	OFF	Stereo Audio Switching (Default = Overlap)
6	OFF	Open Collector and Relay configuration
7	OFF	Power up modes (Default = Last source selected)
8	ON	Remote Control / "PIP / Triggers" (Default)

Unit ID Address DIP-switches

Switch-1	Switch-2	Mode
OFF	OFF	ID = 0
ON	OFF	ID = 1
OFF	ON	ID = 2
ON	ON	ID = 3

Baud Rate DIP-switch

Switch 3	Mode
OFF	9600
ON	38400

WEBSITE:

Visit our web site for product updates and additional information.



Audio Switch Mode DIP-switches

Switch 4	Switch 5	Mode
OFF	OFF	Overlap
ON	OFF	Interlock
OFF	ON	Interlock
ON	ON	Mix

Open Collector/Relay Mode DIP-switch

Switch 6	Function
OFF	Burst mode control.
ON	Follow / MUX mode.

Power-up Mode DIP-switch

Switch 7	Function
OFF	Last Source Selected
ON	Use the serial "Burst" mode command *0CPS to store the current selected input/output configuration for power-up

Remote / "PIP" (Triggers) Mode DIP-switch

Switch 8	Function
OFF	Remote Control
ON	"PIP"/Triggers enabled

WEBSITE:

Visit our web site for product updates and additional information.



Connecting the RS-232 Serial Port

The multi-drop RS-232 transceiver always switches between transmit and receive mode, unless the unit ID is zero. In that case, the unit will always leave the RS-232 transceiver enabled. Use the provided modular (S9) 9-pin D-sub connector adapter and reversed modular cord to connect the ACS 4.4 G2's serial connector to your serial port.

RJ-11 Adapter Pin	DB-9 D-SUB Pin #	Product's point of view Function Name.
4	3	RS-232 Receive
3	2	RS-232 Transmit
2	5	Ground

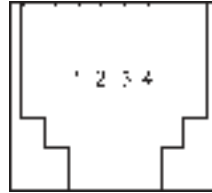

Modular Jack Pin Numbers

The ACS 4.4 G2 is supplied with a standard reverse modular (RJ11 6p4c) telephone voice cable and a Broadcast Tools S9, 9-pin female D-sub modular adapter for serial control. Only use the modular cord that is supplied with the ACS 4.4 G2 or a replacement that reverses (X-over). Connect the cable between the ACS 4.4 G2 and your computer's COM port or USB adapter cable (optional). The ACS 4.4 G2 may be serially controlled at baud rates of 9600 or 38400 baud. The unit is shipped set for 9600 baud, with 8 data bits, no parity and one stop bit. Use a serial terminal like PuTTY, Tera Term, or HyperTerminal using the protocol of 9600-N-8-1. Set the mode to: DIRECT, Flow Control to: NONE and emulation to: ANSI. PuTTY and HyperTerminal set up instructions are available on our web site under "Downloads".

WEBSITE:

Visit our web site for product updates and additional information.



Connecting Multiple ACS 4.4 G2's to a Single Serial Port

Multiple ACS 4.4 G2 switchers may be cascaded serially to operate from the same serial port. The first step is to assign unit IDs to each ACS 4.4 G2. For example: you can assign unit ID 1 to the first switcher and unit ID 2 to the second switcher. You must parallel the serial ports of the ACS 4.4 G2's, to do this plug the male end of a duplex modular adapter (Allen-Tel AT202-6) into the supplied female (S9) DB-9 to RJ-11 adapter, then attach the supplied modular line cords into each of the duplex modular adapter receptacles and the other ends into each ACS 4.4 G2 modular receptacles. See the diagram below. NOTE: Up to four ACS 4.4 G2's may be daisy chained by using the above description and an Allen-Tel AT150, 5-jack modular adapter.

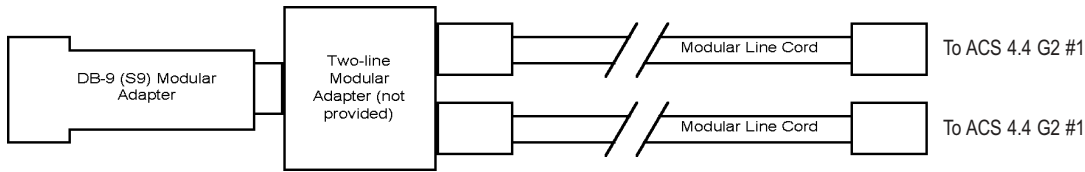

Serial Burst Mode Commands

Burst mode allows a computer or ASCII terminal to control and interrogate the unit. This section defines all burst mode commands accepted by the ACS 4.4 G2. Each burst mode command starts with an asterisk (*) followed by a single decimal digit that corresponds to the unit (ID) address 0-3 and one or more ASCII characters specifying the command. No carriage-return or linefeed is required to terminate the command except for those few commands of variable length if the maximum length is not sent. If the command requested a response, the response would consist of an upper case "S", followed by the unit address, and then the specific response. If acknowledgements are enabled, successful commands are responded to with "RRR" while errors get an "EEE" response. The syntax of each command is given below. The syntax shows the command exactly as it should be sent, except that lower case characters represent values that should be substituted.

WEBSITE:

Visit our web site for product updates and additional information.



Glossary Of Command Notation

Character String	Meaning	Allowable Values
u	Unit ID	0-3
ii	Input Number	01-04
o	Output Number	1-4
r	Relay Output Number	1-4
o	Open Collector Output Number	1-4

Set-up Commands

*0MM - Open setup menu. Unit ID 0 only.

*uCE_x - Enable Error and Good Responses - Where x = Y to enable and N = disable. In this mode, when a command is sent that is in error, the unit will reply (possibly before receiving the entire command) with “EEE.” If the command is sent correctly, the unit will reply with “RRR.”

*uCDEF - Set factory defaults.

*uCII_{ttt} - Set “PIP” Programmable Pulse Stretcher Input Duration = ttt: 000 → 255 hundredths of seconds (255 = 2.55 Seconds)

*uCL_x - Lock Front Panel if x is “L”. Unlock Front Panel if x is “U”

*uCPR - Power up audio state: Restore audio from power up state

*uCPS - Power up audio state: Save power up state

*uCR_{tt} - Set Relay Momentary Pulse Length – tt: 00-99 for 00 → 9.9 Seconds

Silence Sensor Set-up Commands

*uCSA_{tttt} - Set silence sensor time delay to tttt seconds (0002 – 9999), 0000 = OFF

*uCSB_{tttt} - Set silence sensor restore delay to tttt seconds (0002 – 9999), 0000 = OFF

WEBSITE:
 Visit our web site for product updates and additional information.



Relay and Open Collector Commands

*uORrF - Unlatch output relay “r”

*uORrL - Latch output relay “r”

*uORrP - Pulse output relay “r”

*uOOoF - Unlatch open collector “o” (Only works in NON-Remote mode)

*uOOoL - Latch open collector “o” (Only works in NON-Remote mode)

*uOOoP - Pulse open collector “o” (Only works in NON-Remote mode)

Audio Switch Control Commands

*uiio - Apply input “ii” to output “o”

*uiiA - Apply input “ii” to ALL outputs

*uiiEott - Start overlap - Apply input ii to output o. After tt tenths of a second, remove all other inputs from output o.

NOTE: Only one at a time can be pending per output. Max time 9.9 seconds

*uE - End overlap if in overlap mode. This applies to all outputs that have changed since the last “end overlap” command was issued.

*uiiMA - Mute input “ii” for all outputs

*uiiMo - Mute input “ii” for output “o”

*uMo - Mute output “o”

*uMA - Mute all outputs

*uB,a,a,a Set all status ignoring mode: Lower 4 bits of A is channel #'s OR'd together + 1, upper 4 bits is 41. NOTE: Input commands MUST be in CAPS.

A = all off

B = 1

C = 2

D = 1 + 2

E = 3

F = 3 + 1

G = 3 + 2

H = 3 + 2 + 1

I = 4 etc

WEBSITE:

Visit our web site for product updates and additional information.



Menu Mode

The command to enter menu mode is: *0MM. The menu mode displays certain parameters and allows for the control and/or configuration of most switcher functions.

Broadcast Tools(R) ACS 4.4G2 V0.3 - Menu

- 1 - Set PIP Minimum (0-2.55 sec). - Now:1.00 (sec)
- 2 - Set Relay/OC Pulse Hold Time (0 - 25.5 sec) - Now: 1.0
- 3 - Set Silence Sense Acquire Delay (sec). - Now: 10
- 4 - Set Silence Sense Restore Delay (sec). - Now: 5
- 5 - Set Silence Sense Thresholds - Now: -25, -25, -25, -25,
- 6 - Lock/Unlock Front Panel - Now: UNLOCKED

- A - Turn ON Audio XPOINT
- B - Turn OFF Audio XPOINT
- C - Save Audio Macro
- D - Load Audio Macro
- E - Save Current Audio State for Power Up
- F - Show Current Configuration and Status

G - Set Factory Defaults

Audio Status:

1->1 2->2 3->3 4->4

Enter Selection, or Q to quit:

WEBSITE:

Visit our web site for product updates and additional information.



Specifications

*Audio Precision Test Equipment

Input Levels:	Max + 24 dBu, balanced, bridging. 20kΩ.
Output Levels:	Four stereo balanced outputs, +24 dBm. @ 600 Ω. / +26 dbu @ 10K . Headphone output, 4.7 Ω. 100mw.
System Gain:	10 dB max.
Frequency Response: *	20 to 20 kHz; +/- .0.25dB
Signal/Noise Ratio: *	>-84 dB nominal, weighted 20 to 22Khz
Distortion: *	Less than 0.02% THD @ +26 dBu
Crosstalk: *	-100 dB @ 1khz / -79 dB @ 10 kHz from adjacent off channel.
Input expansion port:	Unbalanced summing inputs @ 10k , 0 dBu.
Switching Method:	Digitally controlled professional level analog switch arrays.
Logic:	Flash microprocessor / Non-volatile memory.
Operation Control:	Front Panel - Momentary switches. Remote /" PIP" (Triggers) - Momentary (40ms to 2.54 seconds response time, compatible with CMOS/TTL logic, open collector or contact closures to ground.
Status/Control:	Serial - Multi-drop RS-232, 9600 or 38.4K, 8, N, 1. Front Panel - LED indicators. Control - 2 - SPDT Relays / Silence Sensor – 4 OC's Remote - 4 - Open collector outputs (6vdc @ 100ma max.) RS-232 - Multi-drop RS-232, 9600 or 38.4K, 8, N,1.
Interfacing:	Audio & Remote Control – RJ45 jacks & Plug-in euroblock screw terminals. Accommodates 16 – 28 AWG wire. Mating connectors supplied for euroblock connectors. RS-232 Serial - RJ-11/6P4C reversed modular cable & "S9" female 9-pin D-Sub adapter supplied. USB-RS-232 Adapter cable and/or Ethernet to serial interface. Optional.
Power:	PS-1515/IEC Universal AC (100-240 VAC, 46-63 Hz w/IEC) input, multi-voltage +/-15vdc) DC switching power supply. CE. (Supplied with domestic IEC AC cord).
Mechanical:	8.50" x 7.10" x 1.576" (WDH) aluminum extrusion chassis with (4) #6-32 screw thread mounting holes for optional RA-1 rack shelf
Weight:	5 lbs. (unit and accessories).

WEBSITE:

Visit our web site for product updates and additional information.



SPECIFICATIONS

LIMITED WARRANTY

The term “Buyer” as used in this document refers to and includes both (but only) (a) any person or entity who acquires such an item for the purpose of resale to others (i.e., a dealer or distributor of an item), and (b) the first person or entity who acquires such an item for such person’s or entity’s own use.

Broadcast Tools warrants to each Buyer of any item manufactured by Broadcast Tools that the item will be free from defects in materials and workmanship at the time it is shipped by Broadcast Tools if the item is properly installed, used and maintained.

EXCLUSIVE REMEDIES

If Broadcast Tools is notified, in writing, of a failure of any item manufactured by Broadcast Tools to conform to the foregoing Limited Warranty within one (1) year following the date of the Buyer’s acquisition of the item, and if the item is returned to Broadcast Tools in accordance with Broadcast Tools’ instructions for confirmation by inspection of the defect (which at Broadcast Tools’ election may include, without limitation, a requirement that the Buyer first obtain a Return Authorization number from Broadcast Tools, that the Buyer furnish proof of purchase in the form of an invoice and/or receipt, and that the Buyer prepay all freight charges associated with any return of the item to Broadcast Tools using such freight service as Broadcast Tools reasonably may specify), Broadcast Tools will repair or replace the defective item, or will refund the purchase price paid by the Buyer for the item. Broadcast Tools shall have the exclusive right to choose between these alternative remedies.

NO OTHER WARRANTIES OR REMEDIES

TO THE MAXIMUM EXTENT PERMITTED BY APPLICABLE LAW, BROADCAST TOOLS AND ITS SUPPLIERS DISCLAIM ALL OTHER WARRANTIES, EITHER EXPRESS OR IMPLIED, INCLUDING BUT NOT LIMITED TO IMPLIED WARRANTIES OF MERCHANTABILITY OR FITNESS FOR A PARTICULAR PURPOSE; AND THE FOREGOING ALTERNATIVE REMEDIES SHALL BE EXCLUSIVE OF ALL OTHER REMEDIES. THIS LIMITED WARRANTY GIVES YOU SPECIFIC LEGAL RIGHTS. YOU MAY HAVE OTHER RIGHTS, WHICH VARY FROM STATE/JURISDICTION TO STATE/JURISDICTION.

NO LIABILITY FOR CONSEQUENTIAL DAMAGES

TO THE MAXIMUM EXTENT PERMITTED BY APPLICABLE LAW, NEITHER BROADCAST TOOLS NOR ANY OF ITS SUPPLIERS SHALL HAVE ANY LIABILITY FOR ANY SPECIAL, INCIDENTAL, INDIRECT, CONSEQUENTIAL OR PUNITIVE DAMAGES WHATSOEVER (INCLUDING, WITHOUT LIMITATION, ANY DAMAGES FOR LOST PROFITS, BUSINESS INTERRUPTION, LOSS OF DATA OR INFORMATION, COST OF CAPITAL, CLAIMS OF CUSTOMERS, OR ANY OTHER PECUNIARY LOSS) ARISING OUT OF THE USE OF OR THE INABILITY TO USE ANY ITEM SUPPLIED BY BROADCAST TOOLS, EVEN IF BROADCAST TOOLS HAS BEEN ADVISED OF THE POSSIBILITY OF SUCH DAMAGES HAVE ANY LIABILITY FOR ANY SPECIAL, INCIDENTAL, CONSEQUENTIAL, EXEMPLARY OR PUNITIVE DAMAGES. THIS LIMITATION OF LIABILITY APPLIES WHETHER A CLAIM IS ONE ALLEGING BREACH OF A CONTRACT OR WARRANTY, NEGLIGENCE OR OTHER TORT, FOR THE VIOLATION OF ANY STATUTORY DUTY, THE FAILURE OF ANY LIMITED OR EXCLUSIVE REMEDY TO ACHIEVE ITS ESSENTIAL PURPOSE, OR ANY OTHER CLAIM OF ANY NATURE. BECAUSE SOME STATES AND JURISDICTIONS DO NOT ALLOW THE EXCLUSION OR LIMITATION OF LIABILITY FOR INCIDENTAL OR CONSEQUENTIAL DAMAGES, THIS LIMITATION MAY NOT APPLY TO YOU.

Broadcast Tools, Inc.

131 State Street
Sedro-Woolley, WA 98284 • USA

360.854.9559 **voice** • 866.783.1742 **fax**
support@broadcasttools.com **e-mail**
www.broadcasttools.com **website**

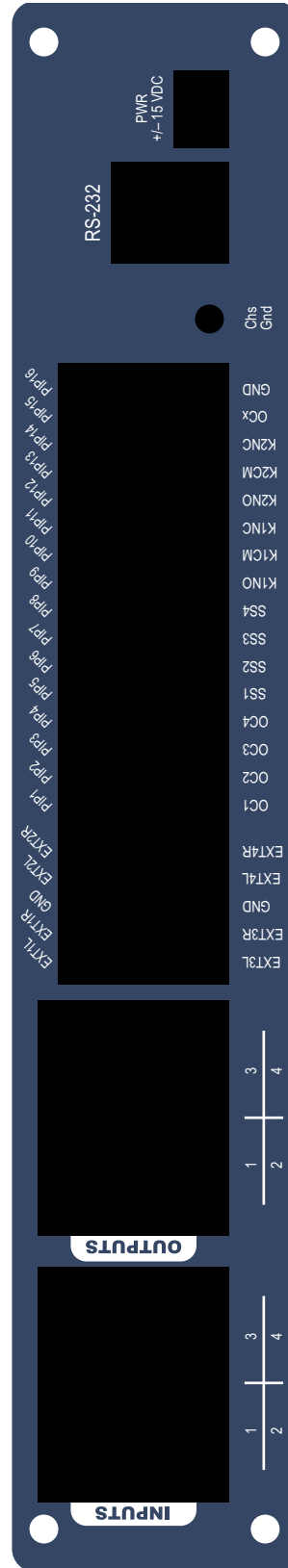

Component Layout

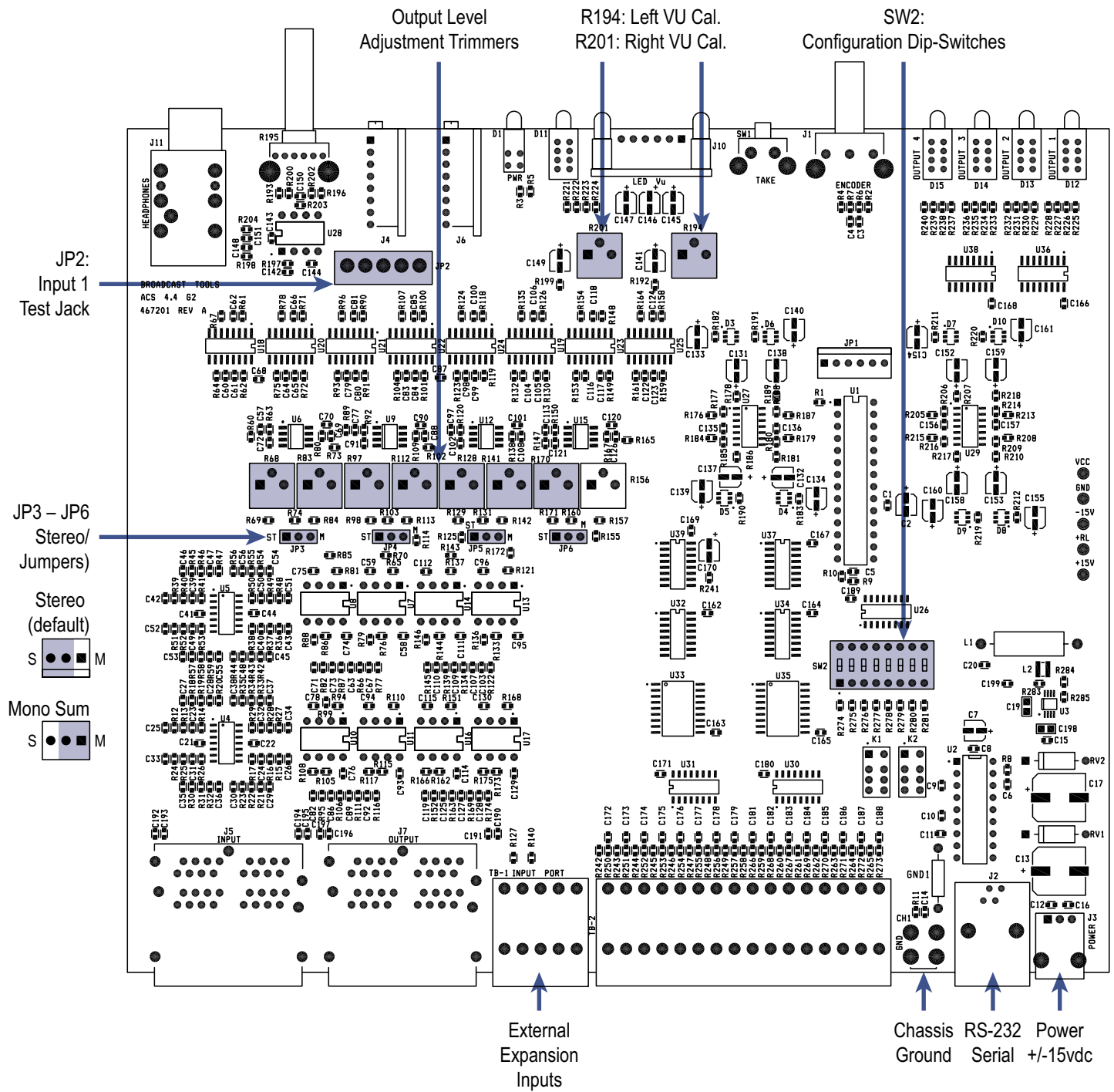

Fractional Schematic

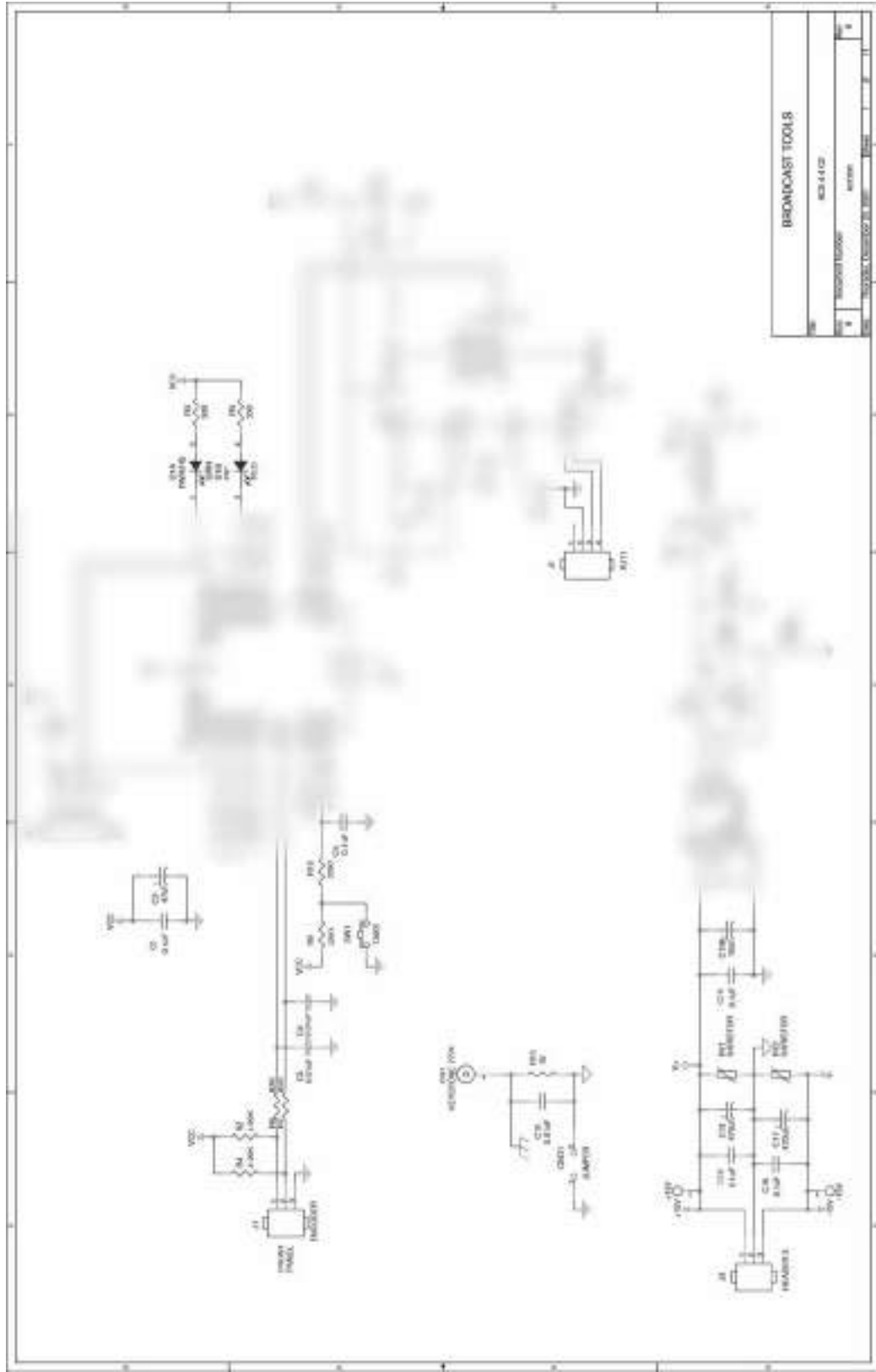

Fractional Schematic

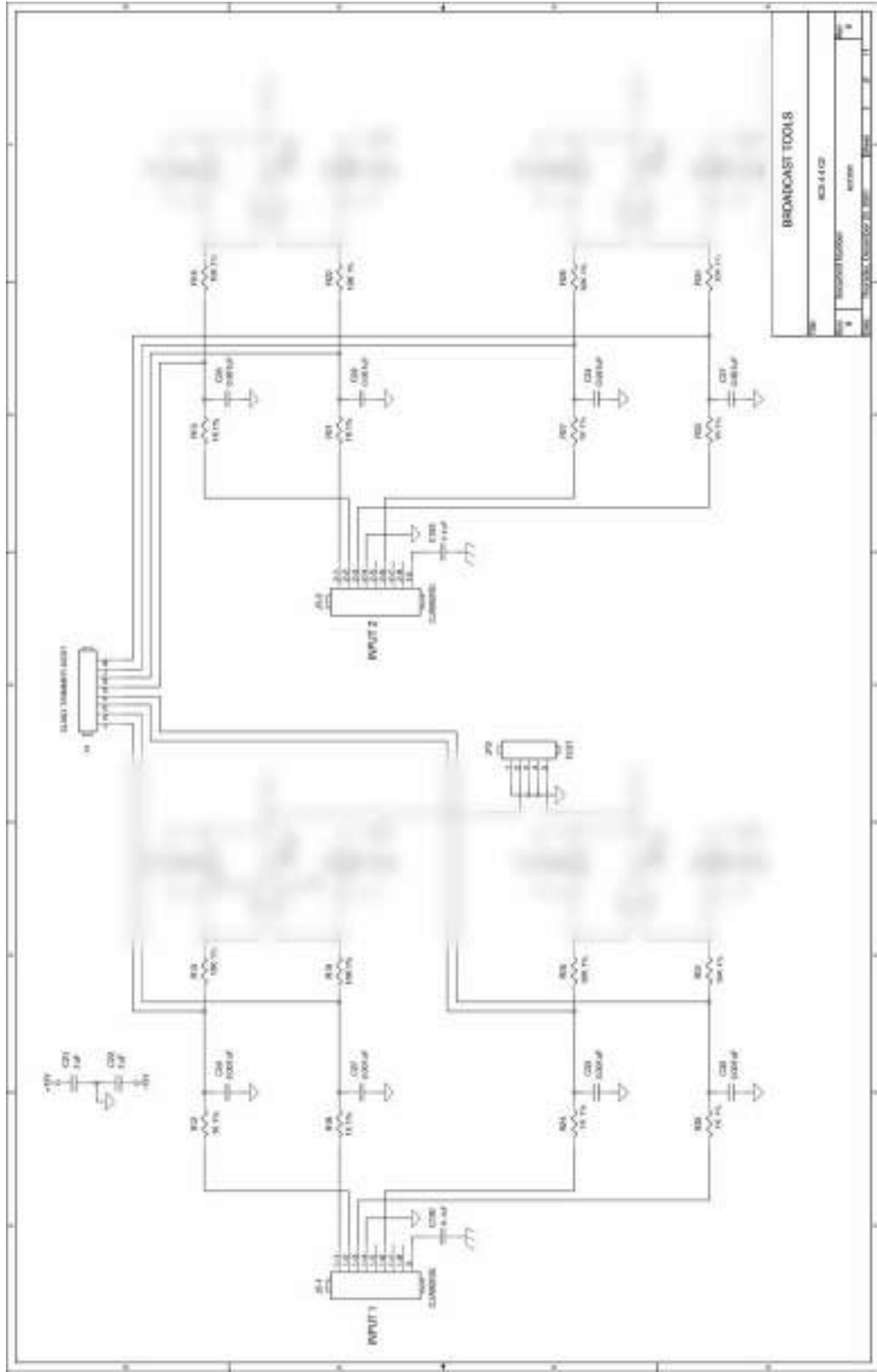

Fractional Schematic

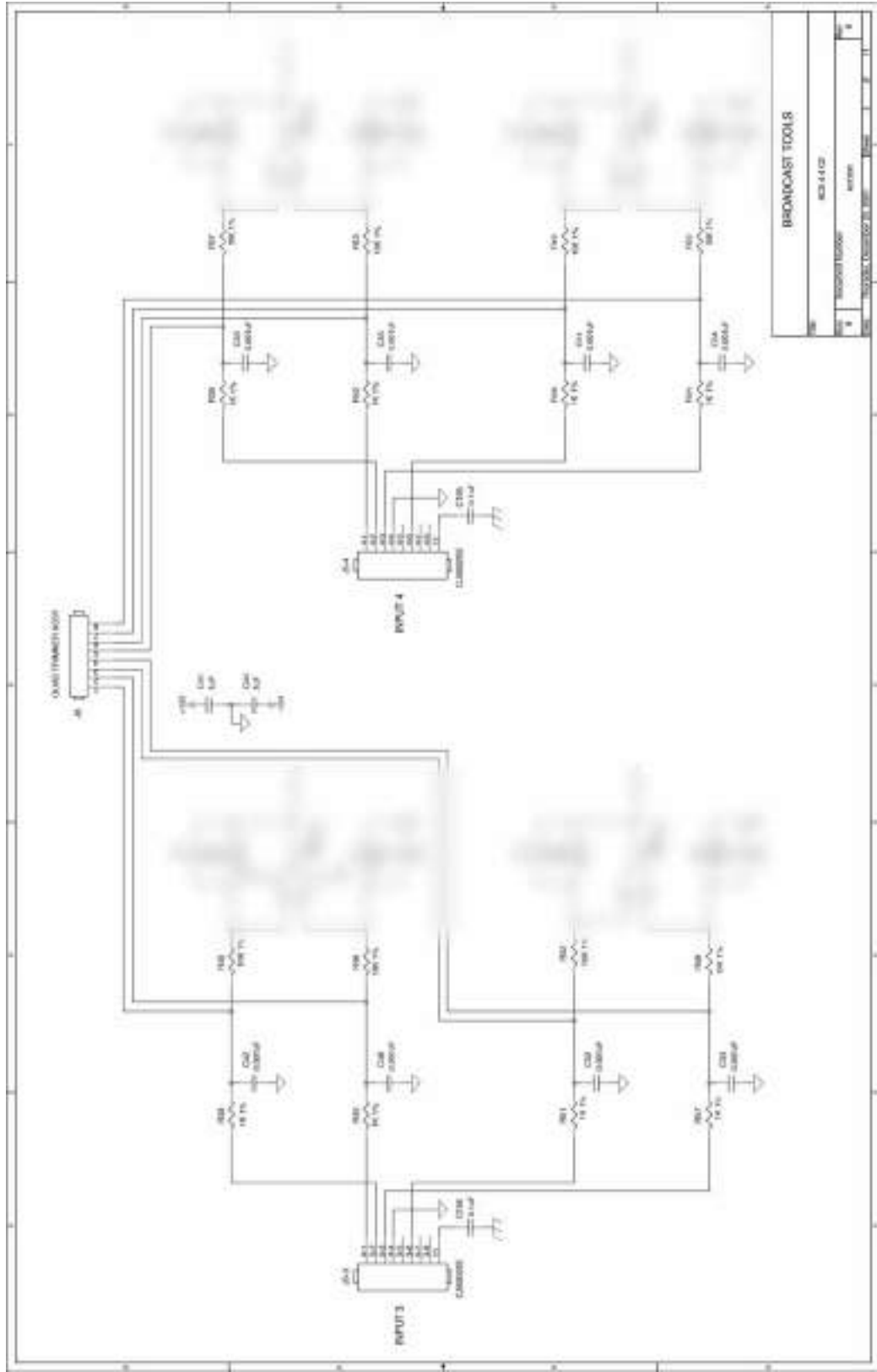

Fractional Schematic

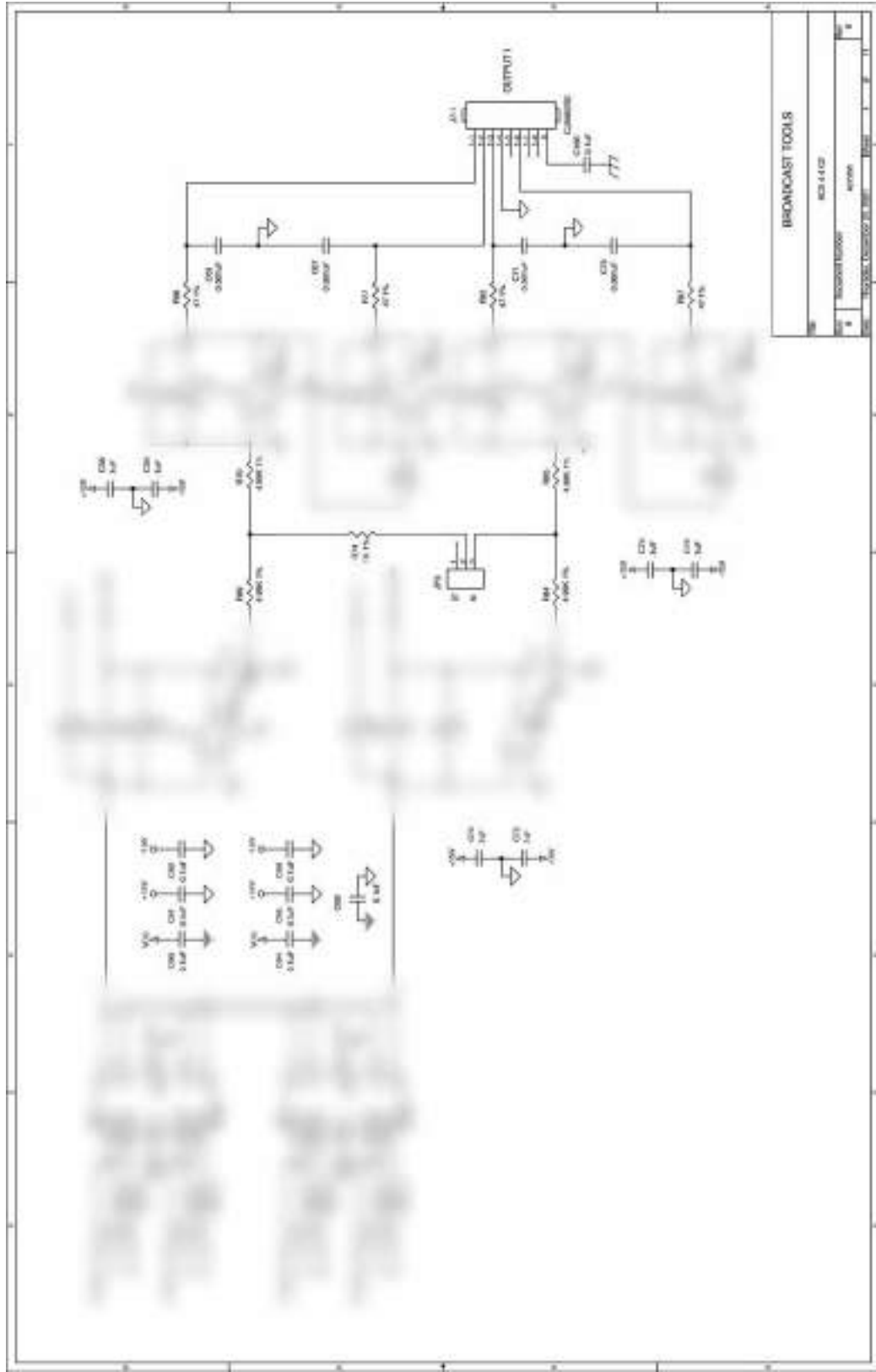

Fractional Schematic

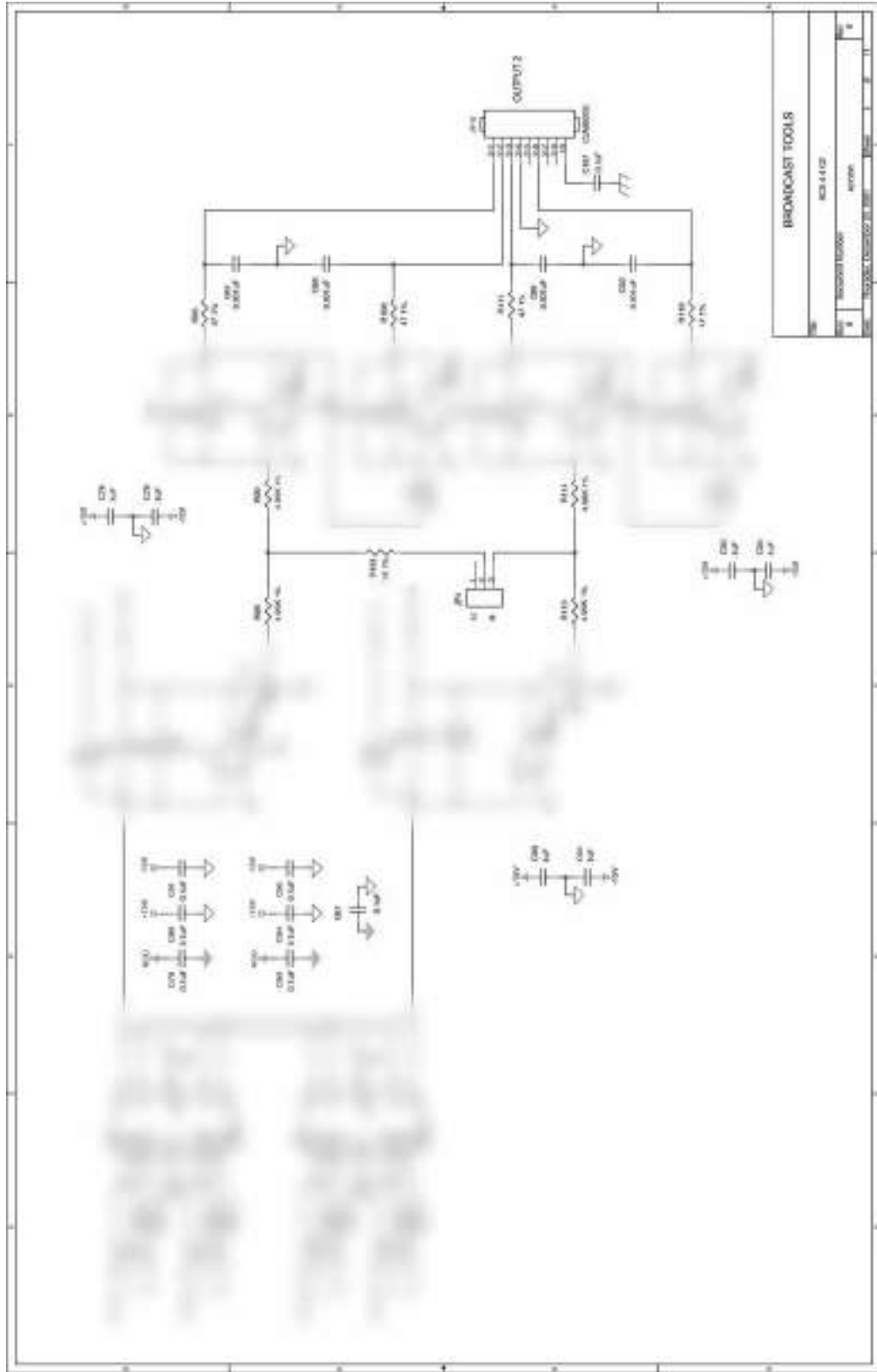

Fractional Schematic

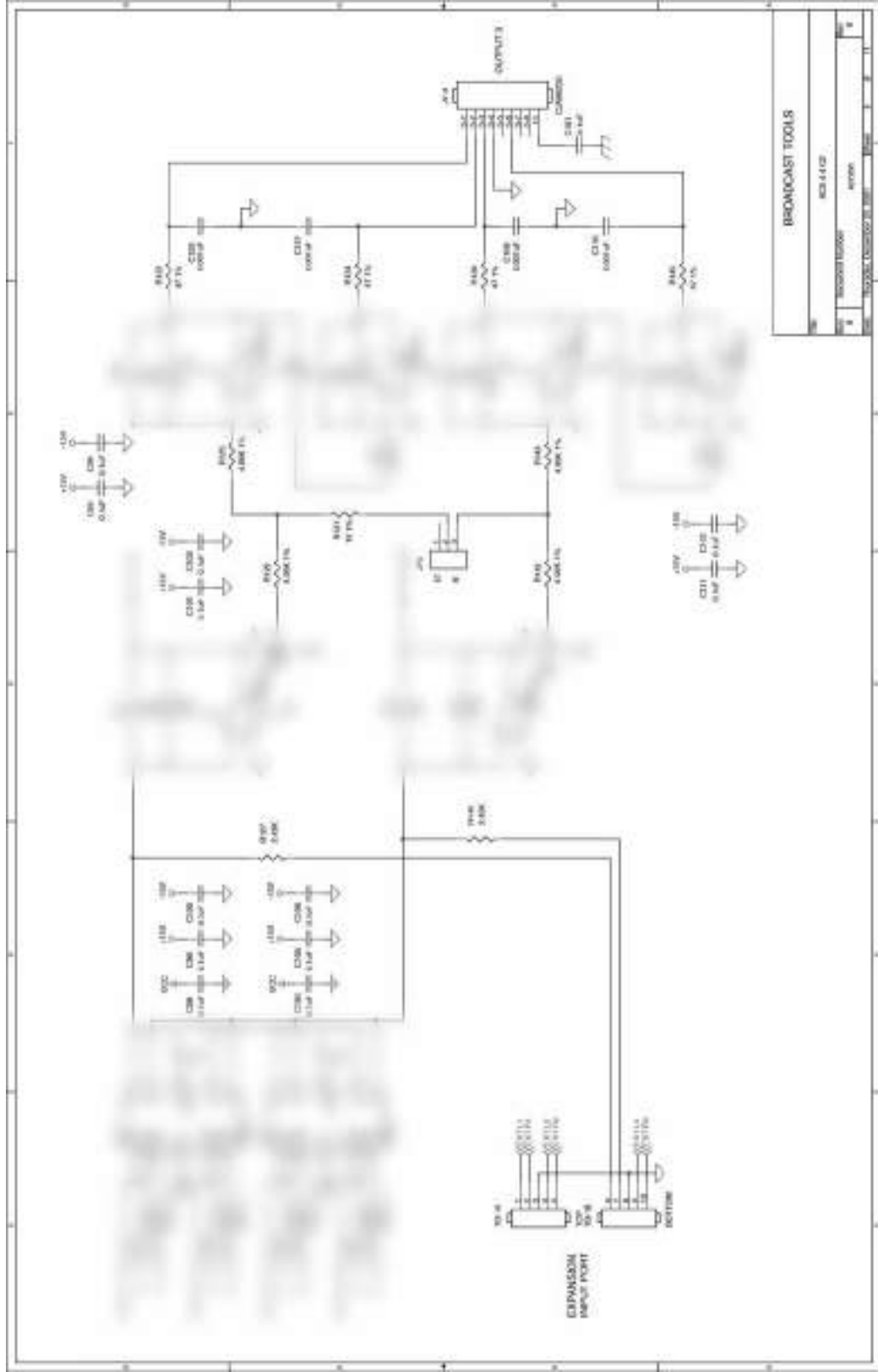

Fractional Schematic

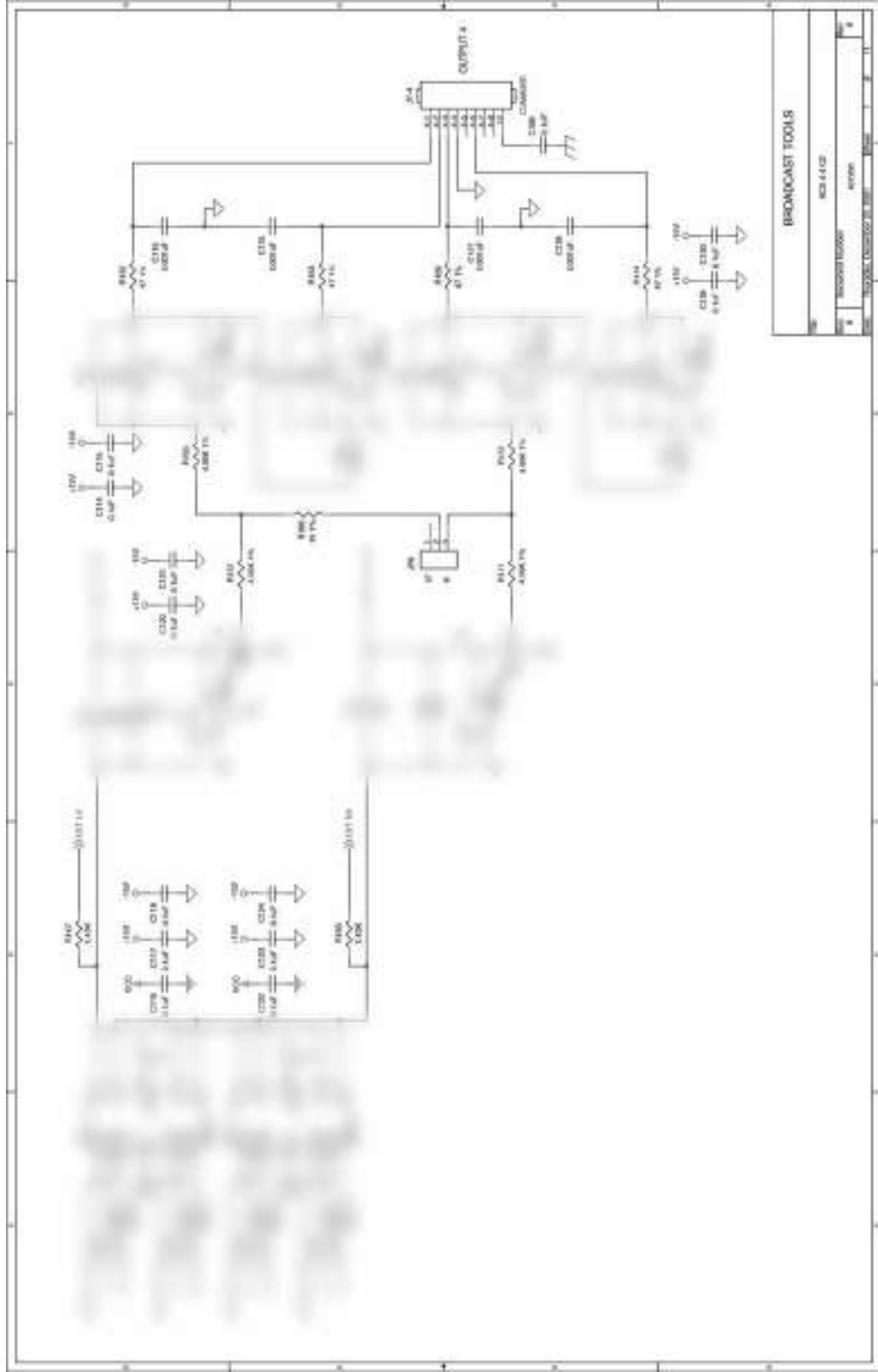

Fractional Schematic

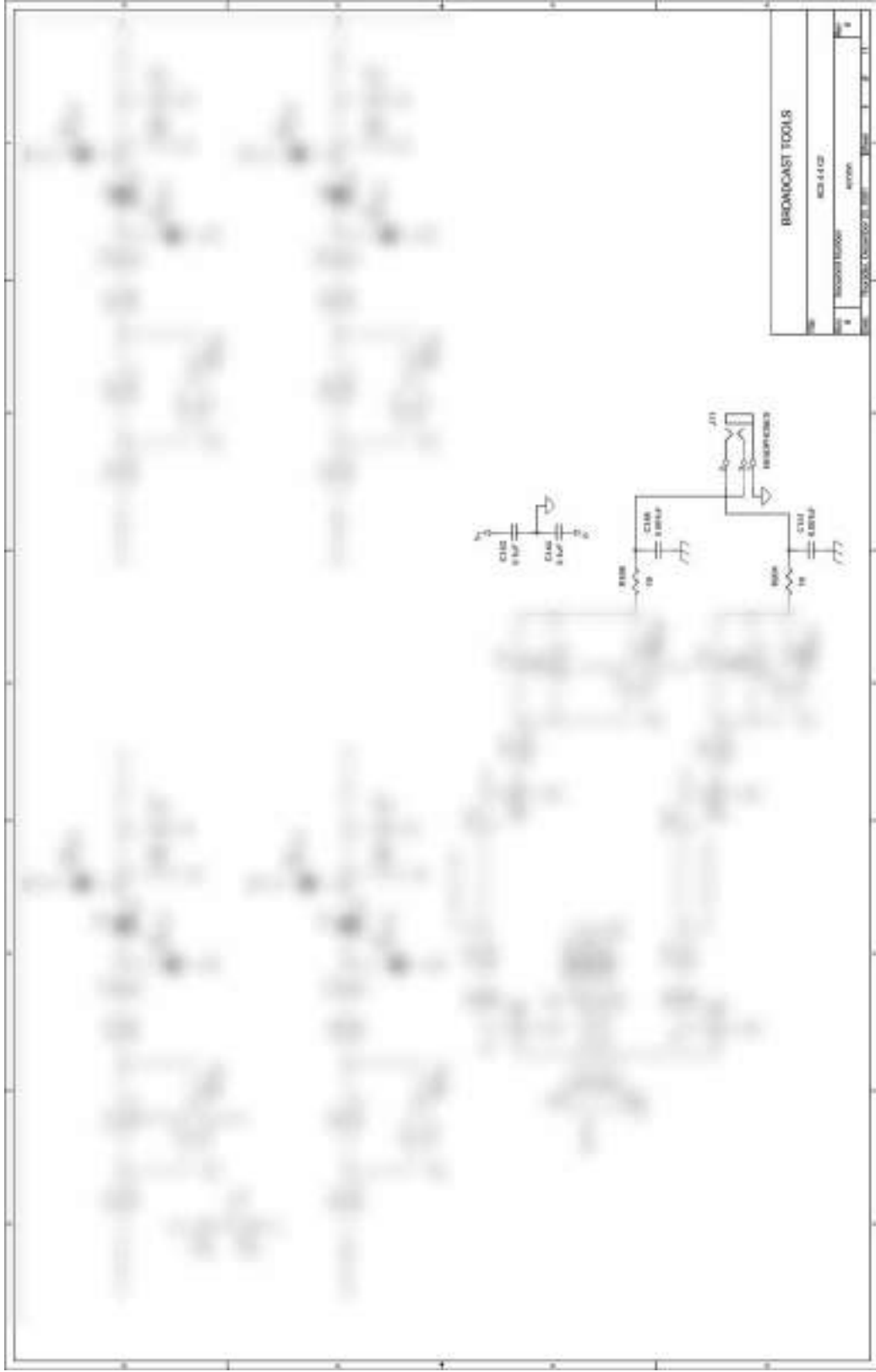

Fractional Schematic

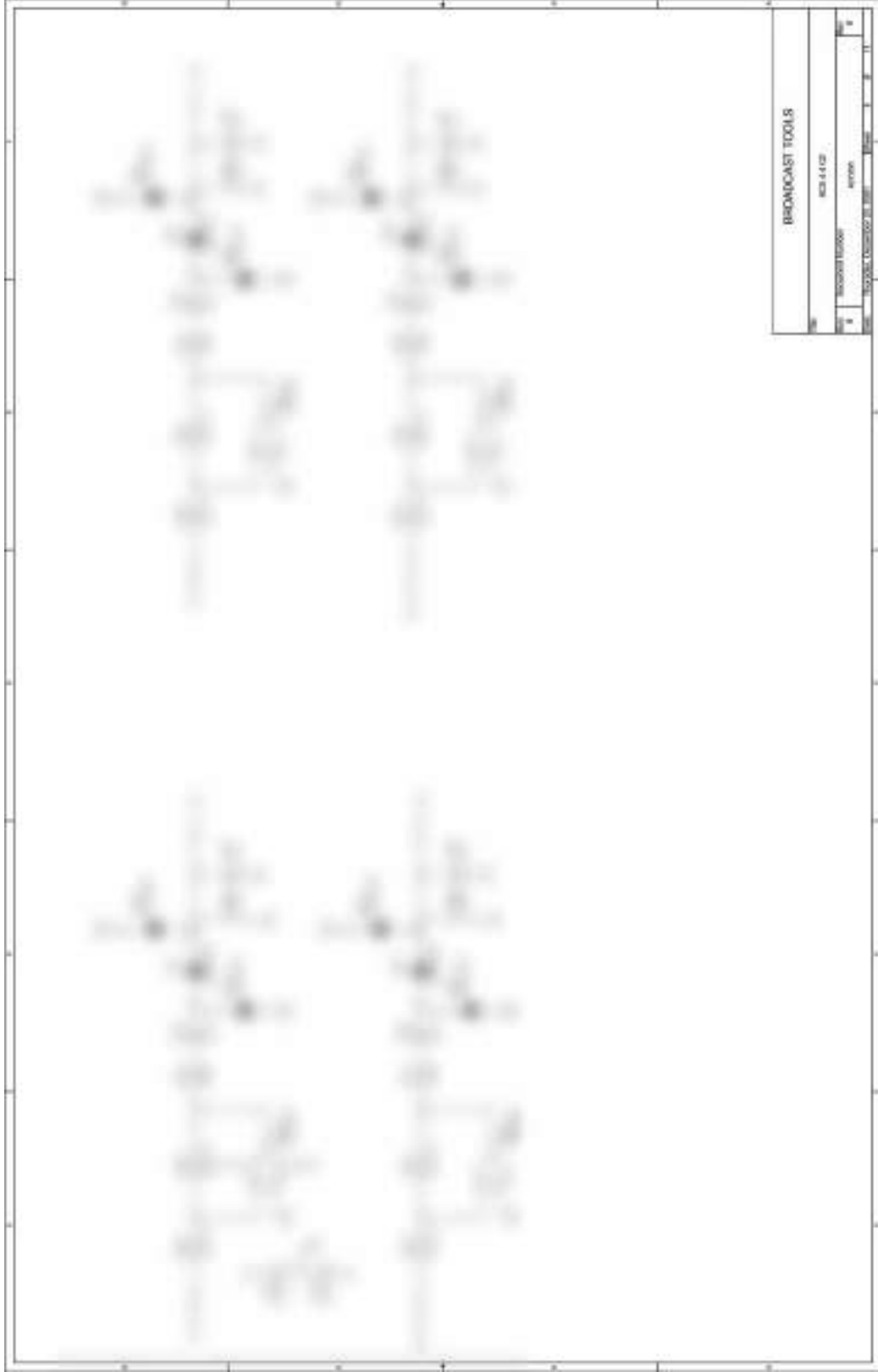

Fractional Schematic

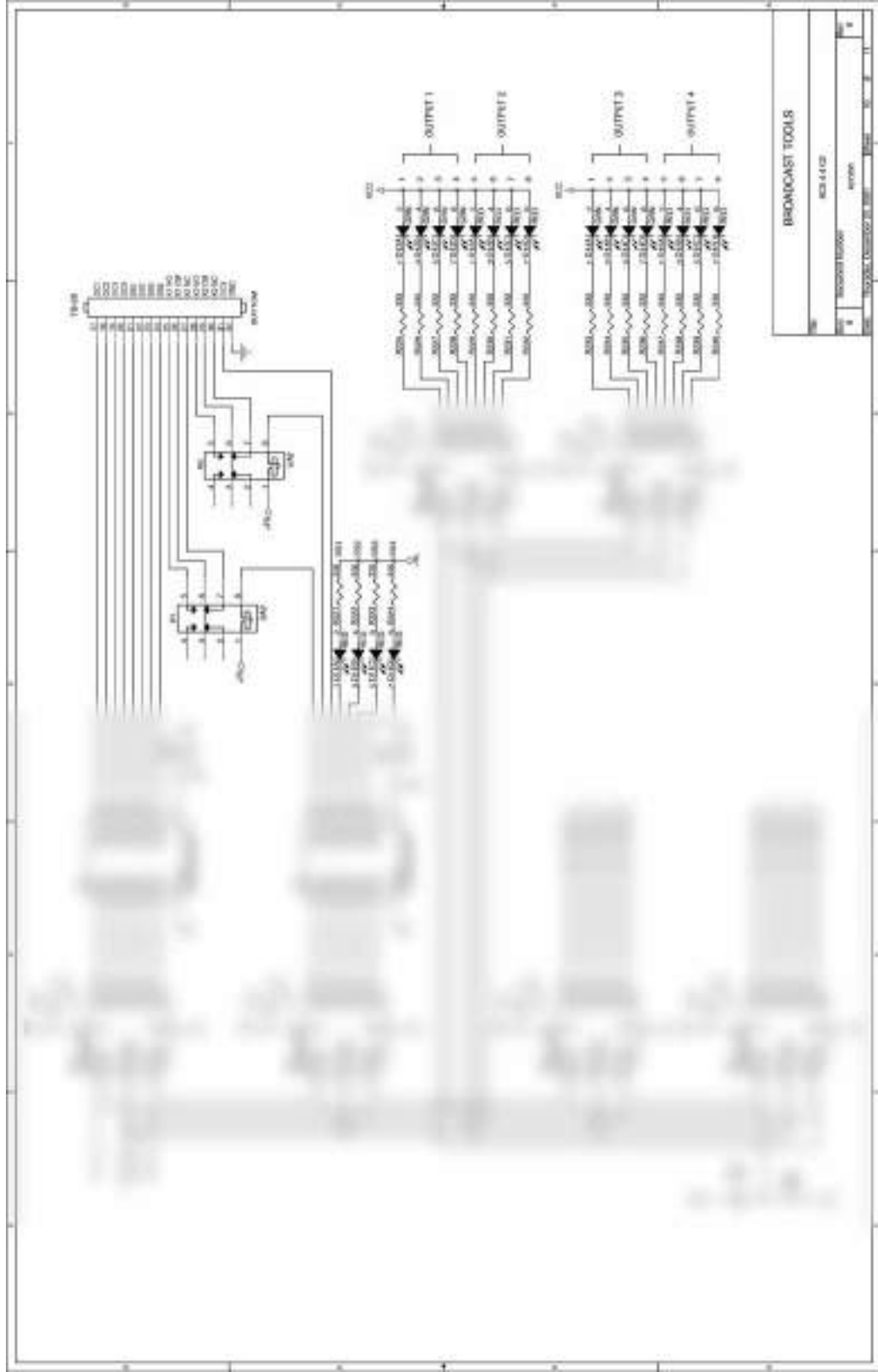

Fractional Schematic

